

**W-5**

**Construction Work of Protection Wall  
at Village Varshamedi of Morbi Cluster.**

**Under SMART ECO VILLAGE - ICZMP**

**PROCUREMENT OF CIVIL WORKS**

**UNDER**

**SHOPPING PROCEDURES**

*(For Works valued less than equivalent of \$ 2,00,000 each)*

**INVITATION FOR QUOTATIONS FOR Construction Work of Protection Wall at Village Varshamedi of Morbi Cluster, Under Smart Eco Village - ICZMP**

**UNDER NATIONAL SHOPPING PROCEDURES**

Dear Bidders,

Sub : **INVITATION FOR QUOTATIONS Construction Work of Protection Wall at Village Varshamedi of Morbi Cluster, Under Smart Eco Village - ICZMP**

1. You are invited to submit your most competitive quotation for the following works:-

<b>Brief Description</b>	<b>Approximate value of the Works</b>	<b>Period of Completion</b>	<b>Tender Fees &amp; EMD</b>
Construction Work of Protection Wall at Morbi Cluster (1) At Village Varshamedi	12.68 Lakhs	30 days	Rs 1,000/- Rs. 12,000/-

2. Government of India has received a credit from the International Development Association (IDA) in various currencies equivalent to 222 million US\$ towards the cost of the Integrated Costal Zone Project and intends to apply part of the proceeds of this credit to eligible payments under the contract for which this invitation for quotations is issued.

3<sup>1</sup>. The Project in the Gujarat state is being implemented by Gujarat Ecology Commission, State Project Management Unit, which is an autonomous society registered under the Societies Registration Act.

4. To assist you in the preparation of your quotation, we are enclosing the following:

- i Detailed Bill of Quantities to fill the rates and amount per tank.
- ii Technical Specifications;
- iii Design & drawings.
- iv. Instructions to Bidders (in two sections).
- v. Draft Contract Agreement format which will be used for finalizing the agreement for this Contract.

<sup>1</sup> Delete if inapplicable

5. You are requested to inspect the site of work before submitting your quotation.
6. You are requested to provide your offer latest by **15:00 hrs. On 28/01/2020.**
7. Quotations will be opened in the presence of Bidders or their representatives who choose to attend at **15:30 hrs. On 28/01/2020.** In the office of Gujarat Ecology Commission.
8. We look forward to receiving your quotations and thank you for your interest in this project.
9. You are requested to attach Demand draft in favour of "**Gujarat Ecology Commission ICZM SPMU**" of **Rs. 1,000** towards **tender fees** which is non returnable and Demand draft or FDR valid for 3 months of **Rs. 12,000** towards **Earnest Money Deposit (EMD)**. EMD will be refunded to unsuccessful bidders after awarding of work to successful contractor.

**Sr. Manager Projects  
Gujarat Ecology Commission**

Address: Block-18, First Floor  
Udhyog Bhavan, Gandhinagar,  
Sector-11

Tel. No. 079-23257659

Fax No. 079-23257657

## **Instructions to Bidders**

## SECTION - A

### 1. Scope of Works

The Gujarat Ecology Commission, SPMU invites quotations for Construction Work of Protection Wall at **Village Varshamedi** of Morbi Cluster, under Smart Eco Village - ICZMP as detailed in the table given below

Brief Description	Approximate value of the Works	Period of Completion	Tender Fees & EMD
Construction Work of Protection Wall at Morbi Cluster (1) At Village Varshamedi	12.68 Lakhs	30 days	Rs 1,000/- Rs. 12,000/-

The successful bidder will be expected to complete the works by the intended completion date specified above.

### 2. Qualification of the bidder:

The bidder shall provide qualification information which shall include:-

- (a) Total monetary value of construction works performed for each year of the last 3 years:
- (b) Report on his financial standing; and
- (c) Details of any litigation, current or during the last 3 years in which the bidder is involved, the parties' concerned and disputed amount in each case.
- (d) Bidder has to attach copies of GST/ PAN numbers and copies of registration etc. to establish legal entity of the bidder.

### 3. To qualify for award of the contract the bidder:-

- (a) To qualify for award of the contract, each bidder in its name should have in the last Three years, *F.Y. 2016-17, 2017-2018 and 2018-2019*
  - (1) Achieved, similar project in at least two financial years, a minimum annual average financial turnover (in all classes of works only) of **Rs. 25.00 lakhs**;
  - (2) Satisfactorily completed, as a prime contractor, (or as subcontractor duly certified by the employer/main contractor) at least one similar work type of value not less than **Rs 10.00 lakhs**.

### 4. Bid Price

- a) The contract shall be for the whole works as described in the Bill of quantities, drawings and technical specifications. Corrections, if any, shall be made by crossing out, initialing, dating and re writing.
- b) All duties, taxes and other levies payable by the contractor under the contract shall be included in the total price.
- c) The rates quoted by the bidder shall be fixed for the duration of the contract and shall not be subject to adjustment on any account.

- d) The rates should be quoted in Indian Rupees only.
- e) BOQ is for one unit of tank.
- f) Price list is to be as total value of contract by multiplication of per tank rate with total numbers.

## 5. Submission of Quotations

5.1 The bidder is advised to visit the site of works at his own expense and obtain all information that may be necessary for preparing the quotation.

5.2 Each bidder shall submit only one quotation.

5.3 The quotation submitted by the bidder shall comprise the following:-

- (a) Quotation in the format given in **Section B**.
- (b) Signed Bill of Quantities; and Signed on each pages of tender document.
- (c) Qualification information form given in Section B duly completed.

5.4 The bidder shall seal the quotation in an envelope addressed to the Sr. Manager Projects, Gujarat Ecology Commission, SPMU, Block No. 18, 1<sup>st</sup> Floor, Udhyog Bhavan, Gandhinagar (Purchaser). The envelope will also bear the following identification:-

- Quotation for Construction Work of **Protection Wall** at Village **Varshamedi** of **Morbi Cluster**, Under Smart Eco Village - ICZMP
- Do not open before **15:30 Hrs. on 28/01/2020**.

5.5 Quotations must be received in the office of the Senior Manager Project, Gujarat Ecology Commission, SPMU not later than the time and date given in the letter of invitation. If the specified date is declared a holiday, quotations shall be received up to the appointed time on the next working day.

5.6 Any quotation received by the Gujarat Ecology Commission, SPMU after the deadline for submission of quotations will be rejected and returned unopened to the bidder.

## 6. Validity of Quotation

Quotation shall remain valid for a period not less than **60 days** after the deadline date specified for submission.

## 7. Opening of Quotations

Quotations will be opened in the presence of bidders or their representatives who choose to attend on the date and time and at the place specified in the letter of invitation. **The representative who intends to attend the quotation opening must hold authorization letter from the parties who has submitted quotation.**

8. Information relating to evaluation of quotations and recommendations for the award of contract shall not be disclosed to bidders or any other persons not officially concerned with the process until the award to the successful bidder is announced.

## 9. Evaluation of Quotations

The Employer will evaluate and compare the quotations determined to be substantially responsive i.e. which

- (a) Meet the qualification criteria specified in clause 3 above;
- (b) Are properly signed; and
- (c) Conform to the terms and conditions, specifications and drawings without material deviations.

**10. Award of contract**

The Employer will award the contract to the bidder whose quotation has been determined to be substantially responsive and who has offered the lowest evaluated quotation price and who meets the specified qualification criteria.

**10.1** Notwithstanding the above, the Employer reserves the right to accept or reject any quotations and to cancel the bidding process and reject all quotations at any time prior to the award of contract.

**10.2** The bidder whose bid is accepted will be notified of the award of contract by the Employer prior to expiration of the quotation validity period.

**11. Retention Money**

Retention money @5% will be deducted from each bill and 50% of retention money will be released after 1 month of work completion and balance 50% of retention money will be released along with performance security.

**12. Performance Security**

Within 10 days of receiving letter of acceptance, the successful bidder shall deliver to the Gujarat Ecology Commission (Employer) the performance security (either a bank guarantee / FDR or a bank draft in favour of "**Gujarat Ecology Commission ICZM SPMU**") for an amount equivalent of **05 % of the contract price**. The Performance Security shall be valid till the expiry of the period of maintenance of the work, specified in clause 13. Failure of the successful Bidder to furnish performance security and signing the agreement within the period stipulated shall constitute sufficient grounds for annulment of award forfeiture of EMD and debarring the bidder for a period of one year, in which case the Employer may make the award to the next lowest evaluated bidder or seek quotations afresh.

**13. Period of Maintenance:**

The "Period of Maintenance" for the work is **12 months** from the date of taking over possession or one full monsoon season whichever occurs later. During the period of maintenance, the contractor will be responsible for rectifying any defects in construction free of cost to the Employer.

**14. Payments under its contract:**

**14.1 Payments to the second party for the construction work will be released by the first party in the following manner:-**

1. Against running bill submission and after certification from TPI and authorized officer of GEC.
2. Final bill will be paid after getting Final bill with certification work completion certificate duly certified by TPI and authorized officer of GEC.

**Note - No advance payment will be made.**

**14.2 Payments at each stage will be made by the first party:**

- (a) To the second party submitting an invoice for an equivalent amount;
  - (b) On certification of the invoice by the engineer nominated by the first party with respect to quality of works in the format in Annexure – 2.
- 15.** Purchase of all construction materials including cement and steel as per the specifications (ISI certification marked goods wherever available) shall be the responsibility of the contractor.

.....



## **Technical Specification**

**PART-I**  
**MATERIALS**

**GENERAL TECHNICAL SPECIFICATIONS FOR BUILDING WORKS as published by R & B Dept. of Govt. of Gujarat to be followed by the contractor.**

**1.1 GENERAL SPECIFICATION OF MATERIALS**

- (1) All materials to be used shall conform to the relevant specifications as per the latest edition of Indian Standard, unless otherwise stated in the detailed specifications of items of work.
- (2) Wherever a reference to any Indian Standard appears in the specification, it shall be taken to mean as a reference to the latest version of the standard.
- (3) Test for material shall be invariably is carried out by the contractor, when the same are specified in the specifications. Tests shall also have to be carried out, even though the same are not specifically mentioned in the specifications but in the opinion of the Engineer-In-Charge, the same are required to be carried out. All such tests shall be carried out in Government Lab or laboratories approved by the Engineer-in-charge and cost there of shall be entirely borne by the Contractor.
- (4) No collection of materials shall be made before it is got approved from the Engineer-In-Charge.
- (5) Collection of approved materials shall be done at site of work in a systematic manner. Materials shall be stored in such a manner as to prevent deterioration or intrusions of foreign matter and to ensure the preservation of their quality and fitness for the work.
- (6) Materials, if rejected by the Engineer-In-Charge, shall be immediately removed from the site of work. If they are not removed within twenty four hours of receiving such intimation, Engineer-In-Charge shall get the same removed at contractor's cost. The Engineer-In-Charge shall dispose off such materials in a manner as he chooses and the contractor shall not be entitled to any compensation for the cost of such materials.
- (7) Approval to the samples of various materials given by the Engineer-In-Charge will not absolve the contractor from the responsibility of replacing the defective material brought on site or materials used in the work found defective at a latter date. The contractor shall have no claim to any payment or compensation whatsoever on account of any such materials rejected by the Engineer-In-Charge.

- (8) The contractor shall be responsible for observing the laws, rules and regulations imposed under the "Mineral Acts" and such other laws and rules prescribed by Government from time to time.

**M-1 WATER:**

Water shall conform to IS: 456.

Water shall not be salty or brackish and shall be clean, reasonably clear and free from objectionable quantities of silt and traces of oil and injurious alkalis, salts, organic matter and other deleterious material, which will either weaken the mortar or concrete or cause efflorescence or attack the steel in RCC. Container for transport, storage and handling of water shall be clean.

If required by the Engineer-In-Charge it shall be tested by comparison with distilled water. Comparison shall be made by means of standard cement tests soundness time of setting and mortar strength as specified in IS-269-1976. Any indication of unsoundness, change in time of setting by 30 minutes or more or decrease of more than 10 percent in strength of mortar, prepared with water sample when compared with the results obtained with mortar prepared with distilled water shall be sufficient cause for rejection of water under test.

Water fit for drinking will generally be found suitable for mortar or concrete.

Water for curing of mortar, concrete or masonry should not be too acidic or too alkaline. It shall be free from elements, which significantly affect the hydration reaction or otherwise interfere with the hardening of mortar or concrete or produce objectionable stains or other unsighting deposits on concrete or mortar surfaces.

Hard and bitter water shall not be used for curing. Potable water will generally be found suitable for curing of mortar or concrete.

**M-2 CEMENT:**

Cement shall be Sulphate Resistant Cement conforming to IS: 12330, Ordinary Portland cement as per I.S. 269-1976 or Portland slag cement as per I.S.455-1976.

The Grade of cement should be of 43 grade or higher grade.

The contractor shall take every precaution to store the cement properly so that it is not spoiled by dampness etc. Cement required for use shall be fresh as far as possible and stored on planks raised 15 to 20 cms above the floor and stacked 30 cms away from the wall in suitable closed weather proof go down at the site of work. Cement shall be stored in such a way so as to allow the removal and use of cement in chronological order of receipt i.e. first received being first used. Not more than 15 bags shall be stacked vertically in one pile and maximum width of the piles should not be more than 3 meters. Any cement, which has deteriorated, caked or which has been set or partially set shall not be used. When temporarily stored in open for use, it shall be kept on a suitable platform and suitably protected as necessary.

Different brands of cement or cement of the same brand from different factories shall be stored in separate groups and shall not be mixed during use. Cement shall be kept in a store under double locking arrangements. A board indicating stock and daily transactions of cement shall be kept in each room of the

cement store. Daily account of receipt and use of cement bags shall be maintained by the Contractor in the proforma prescribed by the Engineer-In-Charge.

The cement shall be measured by no. of bags for all use in concrete (except otherwise stated) and masonry etc. In no case, cement shall be measured by boxes or other means for the volumetric proportion of concrete and mortar. For calculation for the proportion, the volume of the cement bag shall be taken as 0.0342 cu.m. (1.20 cft.) And measuring box of size of 30 cm x 30 x 38 cms for concrete works. If weigh-batch concrete is to be used, the cement shall have to be used as per actual weight and the contractor shall not be entitled for any compensation for loss in weight due to shifting of bags or on account of any other reasons. The cement should be brought from Major Plants

**M-3 SAND:**

Sand shall be natural and, clean, well graded, hard, strong, durable and gritty particles free from injurious amounts of dust, clay, kankar nodules, or of flaky portion, alkali, salts, organic matter, loam, mica or other deleterious substances and shall be got approved from the Engineer-In-Charge. If sand is covered with dust, it shall be washed with water to make it clean.

(A) The sand to be used in cement mortar for masonry works and first coat of plaster should generally satisfy the following grading.

<b>I.S. Sieve</b>	<b>Percentage by weight passing sieve</b>
480	100
230	80-95
120	70-90
60	40-85
30	5-50
15	0-10

The fineness modulus shall not exceed 3.0

(B) Sand to be used in cement mortar for lining work, pointing and second coat of plaster may have the following gradings:

*Sieve percentage by weight passing through*

480	100
240	100
120	75-100
60	40-85
30	5-50
15	0-10

The fineness modulus shall not exceed 1.6

(C) Sand to be used for concrete works shall of grades as specified in I.S. 383. Fineness modulus varying from 2.6 to 3.6 as per requirement.

**M-4 BLACK TRAP GRIT:**

Grit shall consist of crushed or broken stone and be hard, strong, dense, durable, clean of proper gradation and free from skin or coating likely to prevent proper adhesion of Mortar. Grit shall generally be cubical in shape and as far as possible flaky elongated pieces shall be avoided. It shall generally comply with the provision of IS-383-1970. Unless special stone of particular quarries is mentioned, aggregate shall be broken from the best black trap stone as approved by the Engineer-In-Charge. Grit shall have no deleterious reaction with cement.

The grit shall conform to the following gradation as per sieve analysis.

<b>I.S. Sieve Designation</b>	<b>Percentage passing for sieve</b>
12.50mm	100%
10.00mm	85-100%
4.75mm	0-20%
2.36mm	0-5 %

The crushing strength of grit will be such as to allow the concrete in which it is used to built-up the specified strength of concrete.

The necessary test for grit shall be carried out as per the requirements of IS: 2386 or as revised from time to time and as per instructions of the Engineer-In-Charge.

**M-5 CEMENT MORTAR:**

**(A) Cément Mortar:**

**Cement:** Cement shall conform to specification M-2.

**Water:** The water shall conform to specification M-1.

**Sand:** The sand shall conform to specification M-3.

**Proportion of Mix:** Cement and sand shall be mixed to specified proportion. Sand being measured by measuring boxes. The proportion of cement will be by volume on the basis of 50 kg. /bag of cement being equal to 0.0342 cu.m. The mortar may be hand mixed or machine mixed as directed by the Engineer-In-Charge.

**(B) Preparation of Mortar:**

In hand mixed mortar, cement and sand in the specified proportion shall be thoroughly mixed dry on a clean impervious platform by turning over at least 3 times or more till a homogeneous mixture of uniform colour is obtained. Mixing platform shall be so arranged that no deleterious extraneous material shall get mixed with mortar or mortar shall flow out. While mixing, the water shall be gradually added and thoroughly mixed to form a stiff plastic mass of uniform colour, so that each particle of sand shall be completely covered with a film of wet cement. The water cement ratio may be adopted as directed by the Engineer-In-Charge.

The mortar so prepared shall be used within 30 minutes of adding water. Only such quantity of mortar shall be prepared as can be used within 30 minutes. The mortar remaining unused after that period or mortar which has partially hardened or damaged shall not be re-tempered or remixed. It shall be destroyed or thrown away.

**M-6 BLACK TRAP STONE COARSE AGGREGATE FOR PLAIN AND ORDINARY REINFORCED CONCRETE.**

Coarse aggregate shall be of machine crushed stone of black trap and be hard strong, dense durable, clean and free in skin and coating likely to prevent proper adhesion of mortar. The aggregates shall generally be cubical in shape. Unless special stones of particular quarries are mentioned, aggregates shall be machine crushed from the best black trap stone as approved by the Engineer-In-Charge. Aggregate shall have no deleterious reaction with cement. The size of the coarse aggregate for plain cement concrete and ordinary reinforced cement concrete shall generally be as per the table given below. However, in case of reinforced cement concrete the maximum limit may be restricted to 6 mm less than the minimum lateral clear distance between bars or 6 mm less than the cover whichever is smaller.

TABLE - SIZE OF COARSE AGGREGATE

I.S. Sieve Designation	Percentage Passing for single and nominal sized aggregate		
	40 mm	20 mm	16 mm
40 mm	85-100	100	-
20 mm	0-20	85-100	100
16 mm	-	-	85-100
12.5 mm	-	-	-
10 mm	0.5	0-20	0-30
4.75 mm	-	0-5	0-5
2.36 mm	-	-	-

**Note:** This percentage may be varied some what by the Engineer-in-charge who considered necessary for obtaining better density and strength of concrete.

Single size coarse aggregates conforming to the requirements in table No.1 above, or following nominal sizes shall be used at site with the other ingredients of concrete as indicated below. The mixing shall be in a mixture or on the 1:2:4 and C.C. 1: 1:2 mixing with the other ingredient of concrete shall be done in the mixture only except for small work.

- (1) C.C. 1:5:10 - Nominal size of aggregate 40 mm
- (2) C.C. 1:4:8 - Nominal size of aggregate 40 mm
- (3) C.C. 1:3:6 - Nominal size of aggregate 40 mm
- (4) C.C. 1:2:4 - Nominal size of aggregate 20 mm
- (5) C.C. 1:1 ½:3 - Nominal size of aggregate 20 mm
- (6) C.C. 1:1:2 - Nominal size of aggregate 20 mm

The grading test shall be taken in the beginning and at the change of the source of materials. The necessary test indicated in IS – 383 and IS – 456 shall have to be carried out to ensure the acceptability. The aggregates shall be stored separately and handled in such a manner to prevent the inter-mixing of different aggregates. If the aggregates are covered with the dust, it shall be washed with water to make it clean. The course/aggregates for plain and reinforced concrete shall be measured by volume in the steel or wooden boxes prepared as per the direction of the Engineer-In-Charge.

**M-7 BLACK TRAP STONE COURSE AGGREGATES FOR CONTROLLED REINFORCED CONCRETE**

Coarse aggregate shall be of machine-crushed stone of black trap and be hard / strong, dense, and durable clean and free from skin and coating likely to prevent proper adhesion of mortar. The aggregates shall generally be cubical in shape. Unless special stones of particular quarries are mentioned, aggregates shall be machine crushed from the best, black trap stone as approved by the Engineer-In-Charge. Aggregate shall have no deleterious reaction with cement. In proportion concrete, the quantity of coarse aggregates shall be determined by weight only. The grading of coarse aggregate shall be controlled by obtaining the aggregate in different sizes and blending them in the right proportions as per concrete mix design approved by the Engineer-In-Charge. The different sizes shall be stocked in separate stockpiles; the grading of aggregates shall be checked as frequently as possible. The frequency for verification of the grading shall be as directed by the Engineer-In-Charge to ensure that the grading is maintained uniform with that of the samples used in the preliminary tests.

The necessary test indicated in IS - 383 and IS - 456 shall have to be carried out to ensure the acceptability of the material. If aggregate is covered with dust it shall be washed with water to make it clean.

**M-8 BRICKS:**

**(A) First Class Bricks**

The bricks shall be hand or machine molded and made from suitable soils and kiln burnt. They shall be free from cracks and flaws and modules of free lime. They shall have smooth rectangular faces with sharp corners and shall be of uniform colour. The bricks shall be molded with a frog of 100 mm x 40 mm and 10 mm to 20 mm deep on one of its flat sides. The bricks shall not break when thrown on the ground from a height of 600 mm.

The size of modular bricks shall be 190 mm x 90 mm x 90 mm. The standard size of bricks shall be 8 ¾" x 4 ¼" x 2 ⅝". Bricks conform to I.S. 1077 in respect of tolerance for sub-class A bricks. The size of the conventional bricks shall be 225 mm x 110 mm x 75mm.

The crushing strength of the bricks shall not be less than 35 kg/sq.cm. The average water absorption shall not be more than 20 percent by weight. A necessary test for crushing strength and water absorption shall be carried out as per I S 4883-1988 for sewer bricks and I S 2212-1962 practice for Brick works and IS: 3495 (Parts I to IV) as directed by the Engineer-In-Charge.

**(B) Second Class Bricks**

The second class bricks shall be similar to first class bricks except that they may be permitted to have slight distorted and rounded edges provided no difficulty shall arise on this account in laying of uniform courses.



### M-9 MILD STEEL BARS

Mild steel bars reinforcement for R.C.C. work shall conform to IS. 432 and shall be of tested quality. It shall also comply with relevant part of IS. 456. All the reinforcement shall be clean and free from dirt, oil, paint, grease, mill scale or loose or thick rust at the time of placing.

Reinforcement steel shall be stored such as to avoid distortion and sags of long length and shall be protected as far as possible from surface deterioration. All bars of the same designation shall be stacked separately as far as possible and distinctly marked.

For the purpose of payment the bar shall be measured correct up to 10 mm length and weight payable worked out at the rate specified below.

(1)	6 mm	0.22 Kg/Rmt.
(2)	8 mm	0.39 Kg/Rmt.
(3)	10 mm	0.62 Kg/Rmt.
(4)	12 mm	0.89 Kg/Rmt.
(5)	14 mm	1.21 Kg/Rmt.
(6)	16 mm	1.58 Kg/Rmt.
(7)	18 mm	2.00 Kg/Rmt.
(8)	20 mm	2.47 Kg/Rmt.
(9)	22 mm	2.98 Kg/Rmt.
(10)	25 mm	3.85 Kg/Rmt.
(11)	28 mm	4.83 Kg/Rmt.
(12)	32 mm	6.31 Kg/Rmt.
(13)	36 mm	7.99 Kg/Rmt.
(14)	40 mm	9.86 Kg/Rmt.

### M-10 TMT BARS: Scope of work:

The scope of work consists of providing and laying mild steel reinforcement and TMT reinforcement for RCC works of various components of the structure. This may be of Tiscon, Sulekhram, SAIL or Punjab Rolling Mill or any other Approved make. This includes cuttings, bending, binding, placing, with all Equipments and labour required for the work as directed by the Engineer-in-charge and all operations covered within the intent and purpose of the Specification.

#### **Bending of Reinforcement:**

Reinforcing steel shall conform accurately to the dimensions shown on relevant drawings and conforming to the relevant IS codes (latest revision)

Bars shall be bent cold to the specified shape and dimensions or as directed by the Engineer-in-charge using a proper bar bender, operated by hand or power to attain proper radii of bends. Bars shall not be bent or strengthened in a manner that will cause injury to the material. Bars bent during transport or handling shall be straightened before being used on work; they shall not be heated to facilitate bending.

The bending of the TMT bars shall be carried out as per the following:

**Operation Size TMT Fe-510**

1 Bend Up to 22 mm dia. 3d

Over 22 mm dia. 4d

2 Rebend Up to 10 mm dia. 4d

Over 10 mm dia. 5d

**Placing of Reinforcement:**

All reinforcing bars shall be accurately placed in the exact position shown on the drawings, and shall be securely held in position during placing of concrete by annealed binding wire not less than 1 mm. in size and conforming to IS: 280 and by using stays blocks or metal chairs, spacer, metal hangers, supporting wires or other approved devices at sufficiently close intervals. Bars will not be neither allowed to sag between supports nor displaced during concreting or any other Operation over the work. All devices used for positioning shall be of no corrodible material. Wooden and metal supports will not extend to the Surface of concrete, except where shown on the drawings, Placing bars on layers of freshly laid concrete as the work progresses for adjusting bar spacing will not be allowed. Pieces of broken stone, brick or wooden blocks shall not be used. Layers of bars shall be separated by spacer bars, precast mortar blocks or other approved devices. Reinforcement after being placed in position shall be maintained in a clean condition until completely embedded in concrete. Special care shall be exercised to prevent any displacement of reinforcement in concrete already placed. To protect reinforcement from corrosion, concrete cover shall be provided as indicated on the drawings. All bars protruding from concrete to which other bars are to be spliced and which are likely to be exposed for an indefinite period shall be protected by a thick coat of neat cement grout. In the case of columns and walls, vertical bars shall be kept in normal position with timber templates having slots accurately cut in for bar position. Such templates shall be removed after the concreting has progressed up to a level just below them. Bars crossing each other, where required, shall be secured by binding wire (annealed) of size not less than 1 mm and conforming to IS : 280 in such a manner that they do not slip over each other at the time of fixing and concreting. As far as possible, bars of full length shall be used. In case this is not possible, overlapping of bars shall be done as directed by the Engineer-in-charge. When practicable, overlapping bars shall not touch each other, but be kept apart by 25 mm or 1 1/4 times the maximum size of the coarse aggregates whichever is greater, by concrete between them. Where this is not feasible, overlapping bars shall be bound with annealed steel wire, not less than 1mm thickness twisted tight in eight shape around the lapped bars. The overlaps shall be staggered for different bars and located at fixed locations only along the span where neither shear nor bending moment is maximum.

**Welding of Bars**

33 per cent of the rods are welded. No pre-warming or post heat treatment is necessary. Interpose temperature should be limited to 200oC with low heat input and equivalent strength low hydrogen type electrode. Suitable means shall be provided for holding the bars securely in position Welding of

TMT bars can be permitted if specified on the drawings, joints of Reinforcement bars shall be butt welded so as to transmit their full strength. Welded joints shall preferably be located at points where steel will not be subject to more than 75 percent of the maximum permissible stresses and welds so staggered that at any one section, not more than during welding. It must be ensured that no voids are left in welding and when welding is done in 2 or 3 stages, previous surface shall be cleaned properly. Ends of the bars shall be cleaned of all loose scale, rust. Grease, paint and other foreign matter before welding. Only competent welders shall be employed on the work. Welded pieces of reinforcement shall be tested. Specimens shall be taken from the actual site and their number and frequency of tests shall be as directed by the Engineer-in-charge..

**M-11 MILD STEEL BINDING WIRE:**

The mild steel wire shall be of 1.63 mm or 1.22 mm (16 or 18 gauge) diameter and shall conform to IS-280 or as revised from time to time.

The use of black wire will be permitted for binding reinforcement bars. It shall be free from dust, oil paint, grease, loose mill scale or any other undesirable coating, which may prevent adhesion of cement mortar.

Storage: The wire coils shall be stored such as to avoid deterioration.

Measurement: No measurement will be taken of the wire used for tying reinforcement bars. The rate for reinforcement steel and its fabrication shall include the cost of binding wire.

**M-12 STRUCTURAL STEEL:**

All structural steel shall conform to IS-226 and IS-800 or as revised from time to time. The steel shall be free from the defects mentioned in IS. 226 and shall have a smooth finish. The Material shall be free from loose mill scale, rust pits or other defects affecting the strength and durability. Rivet bars shall be conforming to IS-1148.

Structural steel shall be stored such as to avoid distortion of section of long length and shall be protected as far as practicable from surface deterioration. It should be so stored and handled that material will not be subjected to excessive stress and damages. All deformed structural material will be properly straightened by methods, which are not injurious prior or being, and off, punched or otherwise worked in the shop. Sharp kinks and bends shall be caused for rejection.

When the steel is supplied by the Contractor test certificate of the manufactures shall be produced, if so required by the Engineer-In-Charge. If further test be necessary, they will be done according to IS-226 and IS-23 or as revised from time to time.

**M-13 SHUTTERING:**

The shuttering shall be either of wooden planking of 30mm minimum thickness with or without steel sheet lining or of steel plates stiffened by steel angles. The shuttering shall be supported on battens and beams and props of vertical ballies properly cross braced together so as to make the form work rigid.

The form work shall be sufficiently strong and shall have camber, so that it assumes correct shape after deposition of the concrete and shall be able to resist forces caused by vibration of live load of men

working over it and other incidental loads associated with it. The shuttering shall have smooth and even surface and its joints shall not permit leakage of cement grout.

If at any stage of work during or after placing concrete in the structure the form work sags or budes out beyond the required shape of the structure, the concrete shall be removed and work redone with fresh concrete and adequate rigid form work. The complete formwork shall be got inspected by and approved from the Engineer-In-Charge before the reinforcement bars are placed in position.

If wooden props are used, the props shall consist of ballies having 100 mm minimum diameter measured at mid length and 80 mm at thin end and shall be placed at 1 to 1.20m spacing. These shall rest squarely on wooden sole places 40 mm thick and minimum bearing area of 0.10 sq.m. Lay on sufficiently hard base.

Double wedges shall further be provide between the sole plate and the wooden props so as to facilitate tightening and easing of shuttering without jerking the concrete.

The timber used in shuttering shall not be so dry as to absorb water from concrete and swell budge nor so green or wet as to shrink after erection. The timber shall be properly swan and planned on the sides and the surface coming in contact with concrete. Wooden form work with metal sheet lining or steel plates stiffened by steel shall be permitted.

As far as practicable clamp shall be used to hold the forms together and use of nails and spikes avoided.

The surface of timber shuttering that would come in contact with concrete shall be well wetted and coated with soap solution before the concreting is done. Alternatively coat of soap solution or raw linseed oil shall be applied after thoroughly cleaning the surface.

The shuttering for beams and slabs shall have camber of 4 mm per meter (1 in 250) or as directed by the Engineer-In-Charge so as to offset the subsequent deflection. For cantilever the camber at free end shall be 1/50 of the projected length or as directed by the Engineer-In-Charge.

The period that shall elapse after the concrete has been laid before easing and removal of centering and shuttering as under taken shall be as follows.

	<b>Part of structure</b>	<b>Period</b>
1.	Sides of Foundation, Columns beams & walls.	24 to 48 hours.
2.	Undersides of slabs up to 4.5 m span.	7 days.
3.	-do- above 4.50 m and under side of Beams and arches up to 6 m span.	14 days.
4.	-do- above 6 m span & upto 9 m. span	21 days.
5.	Inner sides of beams and arches over 9 m span.	28 days.
6.	Domes, shell & other structures of Special nature.	as per instruction

Work damaged through premature or careless removal of forms shall be reconstructed.

The period for striking the form work shall be 0.5 times more in case of Puzzoloana Cement if used than that of the ordinary Portland cement and the contractor shall not entitle for any extra claim for the same.

**B) STONEWARE PIPES AND FITTINGS**

The pipes and fittings shall be of best quality as approved by the Engineer-In-Charge. The pipe shall be of best quality and as per I S 651-1980 manufactured from stoneware of fire clay, salt glazed thoroughly burnt through the whole thickness, of a close even texture, free from air blows, fire blisters, crack and other imperfections, which effect the serviceability. The inner and outer surfaces shall be smooth and perfectly glazed. The pipe shall be capable to withstand pressure of 1.5m head without showing sign of leakage. The thickness of the wall shall not be less than 1/12<sup>th</sup> of the internal dia. The depth of socket shall not be less than 38mm. The socket shall be sufficiently large to allow a joint of 1 mm around the pipe. All pipes with spigot and socket ends shall conform to IS.651 and shall be of grade 'A'. These shall be sound, free from visible defects such as fine cracks or hair cracks. The glaze of the pipes shall be free from crazing. The pipes shall give a sharp clear noise when struck with a light hammer.

The following information shall be clearly marked on each pipe and fitting:

- (a) Internal diameter;
- (b) Grade;
- (c) Date of manufacture;
- (d) Name of manufacturer or his registered trade-mark or both.

The dia, thickness and weight of stone ware pipe as per IS shall be as below:

Internal Dia of Pipe mm	Mean thickness of barrel and of socket mm	Weights of each pipe 60 cm long. kg approx
100	12	14
150	16	22
200	17	33
250	20	52

**M-14. Teak wood:**

The teak wood shall be of good quality as required for the item to be executed. When the kind of wood is not specifically mentioned, good Indian teak wood as approved shall be used.

Teak wood shall generally be free from large, loose, dead or cluster knots, flaws, shakes, warps, twists bends or any other defects. It shall generally be uniform in substance and of straight fibres as far as possible. It shall be free from rot, decay, harmful fungi and other defects of harmful nature which will affect the strength durability of its usefulness for the purpose for which it is required. The colour shall be uniform as far as possible. Any effort like painting, using any adhesive or resins materials made to hide the defects shall render the pieces liable to rejection by the Engineer-in-charge. All scantlings, planks etc. shall be sawn in straight lines and planes in the direction of grains and of uniform thickness.

The tolerances in the dimensions shall be allowed at the rate of 1.5 m.m. per face to be planed.

**First class teak wood:**

First class teak wood shall have no individual hard and sound knots, more than 6 sq. cm. size and the aggregate area of such knots shall not be more than 1% of area of piece. The timber shall be closed grained.

**Second Class Teak Wood:**

No individual hard and sound knots shall be more than 15 Sq. cms. in size and aggregate area of such knots shall not-exceed 2% of the area of piece.

**CODE OF PRACTICE**

**GENERAL:**

- (1) The method of the execution of the items shall conform to the relevant specifications as per the latest version of the Indian Standard; List of applicable Indian Standards **annexed** below, unless specified otherwise and as far as is applicable.
- (2) Wherever a reference to any Indian Standard appears in the code, it shall be taken to mean as a reference to the latest version of the Standard.
- (3) Work Tests shall invariably be got carried out by the Contractor, when the same are specified in this Code. Tests shall also have to be carried out, even though the same may not have been specifically mentioned in the Code, if in the opinion of the Engineer-In-Charge, they are required to be carried out. All the tests shall be got carried out in Government or approved laboratories and cost there of shall be entirely borne by the Contractor. All moulds, equipments, etc. required of preparing specimens for tests shall be kept in sufficient numbers and in good state, as directed by the Engineer-In-Charge, on the site of work. Specimen for tests shall be, sent to the Laboratory along with the representative of municipality/ consultant in time and the results thereof shall be promptly obtained and reported to the Engineer-In-Charge.
- (4) Satisfactory test results shall not absolve the Contractor, from dismantling and re-doing any work revealed to be defective at a later date. The contractor shall have no claim for any payment or compensation whatsoever on account of replacement of such defective work. Contractor shall take all precautions and care during dismantling and re-doing the work to ensure that any other work, so far executed does not get damage or affected.
- (5) The work shall be carried out in true line and level, and in conformity with the detailed drawings and specified patterns.
- (6) All work shall be carried out in a workman-like manner and as per the best techniques for the particular item.
- (7) All tools, templates, equipments etc. for correct execution of the work, as well as for checking lines, levels alignments of the works, during execution shall be kept in sufficient numbers on the site of work.
- (8) All installations pertaining to water supply and drainage lines fixtures as well as and sanitary fittings shall be deemed to be completed only after giving satisfactory test by the Contractors.
- (9) Scaffolding shall be provided by the Contractor at his own cost for such of the items for the execution of which it is essential

**CODE OF PRACTICE**

**List of I S (Indian Standard) For DRAINAGE WORKS**

<b>Sr.No</b>	<b>I S number</b>	<b>Particulars of Code</b>
1	651-1980	Code of Practice for Stone Ware Pipes and Fittings
2	4127-1983	Code of practice for laying of Stone ware pipe
3	458-2003	Code of practice for Concrete Pipe (with & without reinforcement)
4	783	Code of practice for laying of Concrete pipe
5	784-1978	Pre Stressed Concrete Pipe
6	3597- 2003	Method of test of Concrete Pipe
7	8329-2000	D.I. Pipe centrifugally cast (spun) for water, Gas Sewerage.
8	12288-1987	Laying of D I Pipe.
9	9523- 2000	D I Fittings/Specials
10	1539-&1536-1989	C I pipe Centrifugally casted (spun) iron pressure pipe for water, Gas and Sewage.
11	3114-1985	Laying of C I pipe
12	5531-1977	C I Fittings/Specials
13	3486-1966	C I Spigot and Sockets drain pipe
14	5455-1969	C I Steps
15	1726	C I Man Hole and Frame Cover
16	1729	Sand C I spigot and sockets soil fittings
17	780-1980	C I Sluice Valve up to 300 mm Dia.
18	2906-1980	C I Sluice Valve above 300 mm Dia.
19	14333-1996	H D P E pipe for sewerage.
20	7634 (Part-2) 1973	Laying and Jointing HDPE Pipe
21	8360 (pat 1 to 3 )	HDPE fabricated fittings
22	8008 (part 1 to 7 )	HDPE fitting injection molded
23	7328-1992	H D Polyethylene material for molding & extrusion
24	4985-1988	P V C Pipe
25	1239	Code of practice for G I Pipe
26	7634	Code of Practice for Plastic pipe
27	1592-2003	Code of practice for A C pressure pipe
28	12709-& 14402	G R P Pipes used for water & Sewerage
29	1592-2003	code of practice for A C pipes & Fittings.
30	6530	Code of practice for laying of A C pressure pipes
31	3589	Electrically Welded steel pipe
32	5504-1969	Spiral Welded pipe
33	5822-1986	Laying of Steel Welded pipe
34	6392-1971	Steel pipe flanges.
35	8062	Code of practice for Cathodic protection
36	4111-1986 Part 1	Code of practice for Man Hole Chamber construction
37	4111-1986 (Part 1 to 4 )	Code of practice for Ancillary Structure in Sewage system Man Hole, Invert Syphon, Flushing Tnak ,Pumping Station.& pumping Main.
38	12592-1991 Part 1 & 2	Precast Man Hole Frame & Cover specification

39	<b>1538</b> -1976 (part1 to10)	General Requirements.
40	<b>3764</b> -1966	Safety code for Excavation Works
41	<b>5382</b> -1985	Rubber Ceiling Ring for Water, Gas & Sewerage
42	<b>12820</b> -1989	Dimensional requirements for Rubber Ring Gaskets
43	<b>4883</b> -1988	Specification for Sewer Bricks
44	<b>2212</b> -1962	Code of practice for Brick works.
45	<b>6280</b> -. 2001	Sewerage Screen.
46	<b>11117</b> -1984	Requirements for High pressure Jetting Machine for Sewerage
47	<b>11397</b> -1985	Attachment Tools for Power Driven Roding Machine.
48	<b>5600</b> -1970	Sewage and Drainage Pumps.
49	<b>6279</b> -1971	Equipment for Grit removal device.
50	<b>10037</b> -1981 (part 1 to 3)	Requirements for Sludge dewatering equipment.
51	<b>11972</b> -1967	Code of practice for Safety precaution to be taken when entering in a Sewage system.
52	<b>10261</b> -1982	Requirements for settling Tank.
53	<b>10552</b> -1983	Buckets to be use in power driven bucket type sewage cleaning machine.
54	<b>10595</b> -1983	Requirements for power driven Bucket type of sewage cleaning machine.
55	<b>210</b>	Specification for Grey Iron Casting
56	<b>269</b>	Specification for ordinary and low heat Portland Cement
57	<b>383</b>	Specification for Coarse and fine aggregates from natural sources for concrete
58	<b>432</b>	Specification for Mild Steel and Medium tensile steel bars and Hard drawn steel wire for concrete reinforcement.
59	<b>456</b>	Code of practice for Plain and reinforcement concrete.
60	<b>516</b>	Methods of tests for strength of concrete
61	<b>554</b>	Dimension for pipe threads where pressure tight joints are required on the threads.
62	<b>774</b>	Flushing Cisterns for Water closets and urinals (Valve less symphonic type)
63	<b>775</b>	C I brackets & Supports for wash basin and sink.
64	<b>1786</b>	Specification for high strength deformed steel bars and wires for concrete reinforcement.
65	<b>1742</b>	Code of practice for building drainage works
66	<b>3370</b> (Prat1 to 5)	Code of practice for concrete structures for storage of liquids
67	<b>269</b>	Specification for 33 Grade ordinary Portland Cement.
68	<b>10262</b>	Recommended guidelines for concrete mix design.
69	<b>12269</b>	Specification for 53 Grade ordinary Portland cement.
70	<b>455</b>	Specification for Portland Slag Cement
71	<b>12330 or 6909</b>	Specification for Sulphate resisting Portland Cement.
72	<b>3696</b>	Safety Code for scaffolds and ladder.(Part1 &2)
73	<b>2720</b>	Method of test for soils (Part 1 to 38)



74	<b>8989</b>	Safety Code for erection of concrete framed structures.
75	<b>6587</b>	Specification for spun hemp yarn.
76	<b>5611-.2002</b>	Code of practice for Waste Stabilization Ponds (Facultative Type)
77	<b>14846</b>	C I Air Valve.
78	<b>226 &amp; 800-1975</b>	Structural Steel
79	<b>1538 P- i to xxii</b>	C I Fitting for pressure pipe.

### **SECTION - B**

- 1. Format for Qualification Information.**
- 2. Format for Submission of Quotation.**
- 3. Format of Letter of Acceptance.**

## QUALIFICATION INFORMATION

### 1 For Individual Bidders

1.1 Principal place of business: \_\_\_\_\_

Power of attorney of signatory of Quotation.

**[Attach copy]**

1.2 Total value of Works 2016-17 \_\_\_\_\_  
Performed in the last 2017-18 \_\_\_\_\_  
Three years (in Rs. Lakhs) 2018-19 \_\_\_\_\_

1.3 Work performed as prime contractor (in the same name) on works of a similar nature over the last three years.

---

<u>Project Name</u>	<u>Name of Employer</u>	<u>Description of work</u>	<u>Contract No.</u>	<u>Value of contract (Rs.Lakhs)</u>	<u>Date of issue of work order</u>	<u>Stipulated period of completion</u>	<u>Actual date of completion</u>	<u>Remarks explaining reasons for delay and work completed</u>
---------------------	-------------------------	----------------------------	---------------------	-------------------------------------	------------------------------------	--	----------------------------------	--

---

Existing commitments and on-going works:

---

<u>Description of Work</u>	<u>Place &amp; State</u>	<u>Contract No. &amp; Date</u>	<u>Value of Contract (Rs. Lakh)</u>	<u>Stipulated period of completion</u>	<u>Value of works* remaining to be completed (Rs. Lakhs)</u>	<u>Anticipated date of completion</u>
(1)	(2)	(3)	(4)	(5)	(6)	(7)

---

\* Enclose a certificate from Engineer concerned.

**1.4** Proposed subcontracts and firms involved.

---

<b>Sections of the works</b>	<b>Value of Sub-contract</b>	<b>Sub-contractor (name &amp; address)</b>	<b>Experience in similar work</b>
*	*	*	*
	*	*	
*	*	*	*
	*	*	
*	*	*	*
	*	*	

---

**1.5** Evidence of access to financial resources to meet the requirements of working capital: cash in hand, lines of credit, etc. List them below and attach copies of support documents.

**1.6** Name, address, and telephone, telex, and fax numbers of the Bidders' bankers who may provide references if contacted by the Employer.

**1.7** Information on litigation history in which the Bidder is involved.

---

<b>Other party(ies)</b>	<b>Employer</b>	<b>Cause of dispute</b>	<b>Amount involved</b>	<b>Remarks showing present status</b>

---

## QUOTATION

\*Description of the Works: Construction Work of **Protection Wall** at Village **Varshamedi** of Morbi Cluster

Locations: (1) At Village Varshamedi

To:

Senior Manager Project,  
Gujarat Ecology Commission- ICZMP  
1<sup>st</sup> Floor, Block No.18, Udyog Bhavan,  
Gandhinagar

Subject: Construction Work of **Protection Wall** at Village **Varshamedi** of Morbi Cluster

Reference : Letter No.....dated.....from.....

Sir,

We offer to execute the Works described in your letter referred to above in accordance with the Conditions of Contract enclosed therewith rates against BOQ line items and the total Contract Price of -

Rs.\*\* \_\_\_\_\_ [ in figures ]

Rs. \_\_\_\_\_ [ in words ].

This quotation and your written acceptance of it shall constitute a binding contract between us. We understand that you are not bound to accept the lowest or any quotation you receive.

We hereby certify that we have taken steps to ensure that no person acting for us or on our behalf will engage in bribery.

We hereby confirm that this quotation is **valid for 60 days** as required in Clause 6 of the Instructions to Bidders.

Yours faithfully,

Authorized Signature : \_\_\_\_\_ Date: \_\_\_\_\_

Name & Title of Signatory : \_\_\_\_\_

Name of Bidder : \_\_\_\_\_

Address : \_\_\_\_\_

\* To be filled in by the Employer before issue of the Letter of Invitation.

\*\* To be filled in by the Bidder, together with his particulars and date of submission at the bottom of this Form.

**LETTER OF ACCEPTANCE  
CUM NOTICE TO PROCEED WITH THE WORK**

**(LETTERHEAD OF THE EMPLOYER)**

Dated: \_\_\_\_\_

To: \_\_\_\_\_ [Name and address of the Contractor]

\_\_\_\_\_  
\_\_\_\_\_  
\_\_\_\_\_  
\_\_\_\_\_

Dear Sirs,

This is to notify you that your Quotation dated \_\_\_\_\_ for execution of the \_\_\_\_\_ for the contract price of Rupees \_\_\_\_\_ [amount in words and figures], is hereby accepted by us.

You are hereby requested to furnish performance security for an amount of Rs. \_\_\_\_\_ (**equivalent to 05% of the contract price**) within 10 days of the receipt of the letter. The Performance Security in the form of Bank guarantee or a Bank draft in favour of .....(Employer) shall be valid till the expiry of the period of maintenance i.e. up to \_\_\_\_\_. Failure to furnish the Performance Security will entail cancellation of the award of contract.

You are also requested to sign the agreement form and proceed with the work not later than \_\_\_\_\_ under the instructions of the Engineer, \_\_\_\_\_ and ensure its completion within the contract period.

With the issuance of this acceptance letter and you're furnishing the Performance Security, contract for the above said work stands concluded.

Yours faithfully,

**Authorized Signature  
Name and title of Signatory**

**Draft Agreement form for**  
Construction Work of **Protection Wall** at Village **Varshamedi** of Morbi Cluster  
Locations: (1) At Village Varshamedi.

**National Shopping**

**ARTICLES OF AGREEMENT**

This deed of agreement is made in the form of agreement on \_\_\_\_\_ day \_\_\_\_\_ month \_\_\_\_\_ 2020 \_\_, between the \_\_\_\_\_ (Employer) or his authorized representative (hereinafter referred to as the first party) and \_\_\_\_\_ (Name of the Contractor), S/O \_\_\_\_\_ resident of \_\_\_\_\_ (hereinafter referred to as the second party), to execute the work of Furnishing work of passing area at office (hereinafter referred to as works) on the following terms and conditions.

**2. Cost of the Contract**

The total cost of the works (hereinafter referred to as the "total cost") is Rs. \_\_\_ as reflected in Annexure - 1.

**3.1 Payments under its contract:**

**Payments to the second party for the construction work will be released by the first party in the following manner:-**

1. Against running bill submission and after certification from TPI and authorized officer of GEC.
2. Final bill will be paid after getting Final bill with certification work completion certificate duly certified by TPI and authorized officer of GEC.

**Note - No advance payment will be made.**

**3.2 Payments at each stage will be made by the first party:**

- (a) To the second party submitting an invoice for an equivalent amount;
- (b) On certification of the invoice by the engineer nominated by the first party with respect to quality of works in the format in Annexure – 2.

**4. Notice by Contractor to Officer In-charge**

The second party, on the works reaching each stage of construction, issue a notice to the first party or the Officer In-charge nominated by the first party (who is responsible for supervising the contractor, administering the contract, certifying the payments due to the contractor, issuing and valuing variations to the contract, awarding extensions of time etc.), to visit the site for certification of stage completion. Within 15 days of the receipt of such notice, the first party or the Officer In-charge nominated by it, will ensure issue of stage completion certificate after due verification.

## 5. Completion time

The works should be completed in **30 days** from the date of this Agreement. In exceptional circumstances, the time period stated in this clause may be extended in writing by mutual consent of both the parties.

6. If any of the compensation events mentioned below would prevent the work being completed by the intended completion date, the first party will decide on the intended completion date being extended by a suitable period:

- a) The first party does not give access to the site or a part thereof by the agreed period.
- b) The first party orders a delay or does not issue completed drawings, specifications or instructions for execution of the work on time.
- c) Ground conditions are substantially more adverse than could reasonably have been assumed before issue of letter of acceptance and from information provided to second party or from visual inspection of the site.
- d) Payments due to the second party are delayed without reason.
- e) Certification for stage completion of the work is delayed unreasonably.

7. Any willful delay on the part of the second party in completing the construction within the stipulated period will render him liable to pay liquidated damages. @ Rs. \*1000/- or 0.05% of contract value whichever is higher per day will be deducted from payments due to him. The first party may cancel the contract and take recourse to such other action as deemed appropriate once the total amount of liquidated damages exceeds 2 % of the contract amount.

**(Note: The amount of liquidated damages per day should be determined at 0.05 % of the contract value of the works and indicated here).**

## 8. Duties and responsibilities of the first party

8.1 The first party shall be responsible for providing regular and frequent supervision and guidance to the second party for carrying out the works as per specifications. This will include written guidelines and regular site visit of the authorized personnel of the first party, for checking quality of material and construction to ensure that it is as per the norms.

- 8.2** The first party shall supply 01 set of drawings, specifications and guidelines to the second party for the proposed works.
- 8.3** Possession of the site will be handed over to the second party within immediate of the agreement.
- 8.4** The Engineer or such other person as may be authorized by the first party shall hold meeting once in a month where the second party or his representative at site will submit the latest information including progress report and difficulties if any, in the execution of the work. The whole team may jointly inspect the site on a particular day to take stock of activities.
- 8.5** The Engineer shall record his observations/instructions at the time of his site visit in a site register maintained by the second party. The second party will carry out the instructions and promptly rectify any deviations pointed out by the engineer. If the deviations are not rectified, within the time specified in the Engineer's notice, the first party as well as the engineer nominated by it may instruct stoppage or suspension of the construction. It shall thereupon be open to the first party or the engineer to have the deviations rectified at the cost of the second party.

## **9. Duties and responsibilities of the second party**

**9.1** The second party shall:

- a) take up the works and arrange for its completion within the time period stipulated in clause 5;
- b) employ suitable skilled persons to carry out the works ;
- c) regularly supervise and monitor the progress of work ;
- d) abide by the technical suggestions / direction of supervisory personnel including engineers etc. regarding building construction ;
- e) be responsible for bringing any discrepancy to the notice of the representative of the first party and seek necessary clarification ;
- f) ensure that the work is carried out in accordance with specifications, drawings and within the total of the contract amount without any cost escalation ;
- g) keep the first party informed about the progress of work ;
- h) be responsible for all security and watch and ward arrangements at site till handing over of the building to the first party ; and



- i) Maintain necessary insurance against loss of materials/cash, etc. or workman disability compensation claims of the personnel deployed on the works as well as third party claims.
- f) Pay all duties, taxes and other levies payable by construction agencies as per law under the contract (First party will effect deduction from running bills in respect of such taxes as may be imposed under the law).

## **10. Variations / Extra Items**

The works shall be carried out by the second party in accordance with the approved drawings and specifications. However, if, on account of site conditions or any other factors, variations are considered necessary, the following procedure shall be followed:-

- a) The second party shall provide the Engineer with a quotation for carrying out the Variation when requested to do so by the Engineer. The Engineer shall assess the quotation, which shall be given within seven days of the request before the Variation is ordered.
- b) If the quotation given by the second party is unreasonable, the Engineer may order the Variation and make a change to the Contract Price which shall be based on Engineer's own forecast of the effects of the Variation on the Contractor's costs.
- c) The second party shall not be entitled to additional payment for costs which could have been avoided by giving early warning.

## **11. Security.**

The Performance Security shall be provided to the Employer no later than the date specified in the Letter of Acceptance and shall be issued in an amount and form and by a bank or surety acceptable to the Employer. The Performance Security shall be valid until a date 28 days from the date of issue of the Certificate of Completion including Maintenance Period in the case of a Bank Guarantee.

## **12. Termination**

12.1 The Employer may terminate the Contract if the other party causes a fundamental breach of the Contract.

12.2 Fundamental breaches of Contract include, but shall not be limited to the following:

- (a) The contractor stops work for 28 days and the stoppage has not been authorized by the Engineer;
- (b) The Contractor has become bankrupt or goes into liquidation other than for a reconstruction or amalgamation;

(c) The Engineer gives Notice that failure to correct a particular Defect is a fundamental breach of Contract and the Contractor fails to correct it within a reasonable period of time determined by the Engineer;

(d) The Contractor does not maintain a security which is required;

12.3 Notwithstanding the above, the Employer may terminate the Contract for convenience.

12.4 If the Contract is terminated the Contractor shall stop work immediately, make the Site safe and secure and leave the Site as soon as reasonably possible.

### **13. Payment upon Termination**

13.1 If the Contract is terminated because of a fundamental breach of Contract by the Contractor, the Engineer shall issue a certificate for the value of the work done less advance payments received up to the date of the issue of the certificate, less other recoveries due in terms of the contract, less taxes due to be deducted at source as per applicable law.

13.2 If the Contract is terminated at the Employer's convenience, the Engineer shall issue a certificate for the value of the work done, the reasonable cost of removal of Equipment, repatriation of the Contractor's personnel employed solely on the Works, and the Contractor's costs of protecting and securing the Works and less advance payments received up to the date of the certificate, less other recoveries due in terms of the contract and less taxes due to be deducted at source as per applicable law.

### **14. Dispute settlement**

If over the works, any dispute arises between the two parties, relating to any aspects of this Agreement, the parties shall first attempt to settle the dispute through mutual and amicable consultation.

In the event of agreement not being reached, the matter will be referred for arbitration. In such cases, both the parties will abide by the decision of the Project Director, SPMU.

**Annexure I**

**BILL OF QUANTITIES & Drawings**

**PRICE SHEET**

<b>Sr. No.</b>	<b>Particular</b>	<b>Nos</b>	<b>Rate (each)</b>	<b>Amount</b>
1	Name of Work:- Construction Work of <b>Protection Wall</b> at Village <b>Varshamedi</b> of Morbi Cluster. Locations: (1) At Village Varshamedi.	01		
				<b>Total Rs.</b> <input type="text"/>

**Amount in Word:**

**(Total rates must be inclusive of all taxes and any other charges.)**

**Actual payment will be based on execution of BOQ items as certified by TPI and authorized officer of GEC.**

**Signature of Contractor**

**Gujarat Ecology Commission, Gandhinagar****Construction Work of Protection Wall at Village Varshamedi of Morbi Cluster, Under Smart Eco Village - ICZMP****Implemented by : Gujarat Ecology Commission, Gandhinagar****BOQ for Protection wall - Varshamedi**

<b>Sr. No</b>	<b>Description</b>	<b>Qty</b>	<b>Unit</b>	<b>Rate</b>	<b>Amount</b>
<b>1</b>	Excavation for foundation upto 1.5 m depth including sorting out and stacking of useful materials and disposing off the excavated stuff 50 Mtr Lead. (A) Loose or Soft soil	360.00	CMT		
<b>2</b>	Providing and laying cement concrete 1:4:8 (1-cement : 4- Coarse sand : 8- graded stone aggregates 40 mm nominal size) and curing complete including cost of formwork in (A) Foundation and Plinth (more than 10 ton)	45.00	CMT		
<b>3</b>	Providing and laying controlled cement concrete M.200 and curing complete including the cost of formwork and reinforcement for reinforced concrete work in (A) Foundations, footings, Base of columns and Mass concrete (more than 10 ton)	76.59	CMT		
<b>4</b>	Brick work using common burnt clay building bricks having crushing strength not less than 35 Kg/Sq.cm in foundation and plinth in cement mortar 1:6 (1- cement : 6 - fine sand) (B) Conventional up to (10 ton)	60.75	CMT		
<b>5</b>	Filling available excavated earth(excluding rock) in trenches, plinth, sides of foundations etc. in layers not exceeding 20 cm in depth consolidating each disposed layers by ramming and watering	159.75	CMT		
<b>6</b>	Extra for brick work in superstructure above plinth level up to floor two level (B) Conventional	62.03	CMT		
<b>7</b>	Providing and laying cement concrete 1:3:6 (1-Cement : 3- Coarse sand : 6- crushed stone aggregates 20 mm nominal size) and curing complete including cost of formwork in (A) Wall Caps / Coping (up to 10 ton)	10.67	CMT		
<b>8</b>	20mm thick sand faced cement plaster on walls upto height 10 meters above ground level consisting of 12mm thick backing coat of C.M. 1:3 (1-cement : 3-sand) and 8mm thick finishing coat of C.M. 1:1 (1-cement : 1-sand) etc. complete.	761.12	SMT		

**Gujarat Ecology Commission, Gandhinagar**

**Construction Work of Protection Wall at Village Varshamedi of Morbi Cluster, Under Smart Eco Village - ICZMP**

**Implemented by : Gujarat Ecology Commission, Gandhinagar**

**BOQ for Protection wall - Varshamedi**

<b>9</b>	Providing TMT Bar FE 500/500D reinforcement for R.C.C. work including bending, binding and placing in position complete up to floor two level (upto 10 ton)	6544.36	KG		
<b>10</b>	Providing & laying weep hole in Abutments, and returns by using A.C. pipe of 100mm including laying in proper grade and jointing the completed as per detailed specification.	101.00	Each		
<b>11</b>	White washing with lime on wall surface (two coats) to give an even shade including thoroughly booming the surface to remove all dirt, dust; mortar drops and other foreign matter.	761.12	SMT		
<b>12</b>	Providing and fixing marble slab including engraving and painting complete. (ii) Size 60cm x 60cm x 4cm.	1.00	Each		

**Total Amount**

**Amount in word :**

**(Total rates must be inclusive of all taxes and any other charges.)**

**Signature of Contractor**

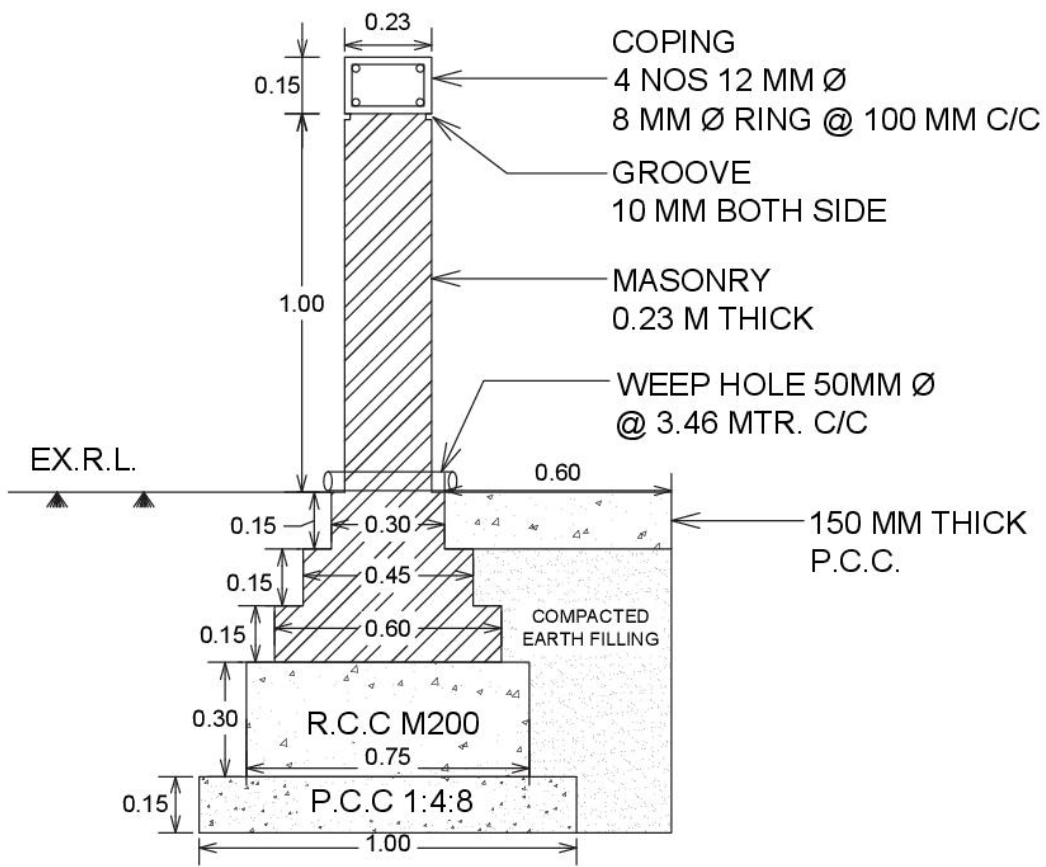

# SECTION:-AA

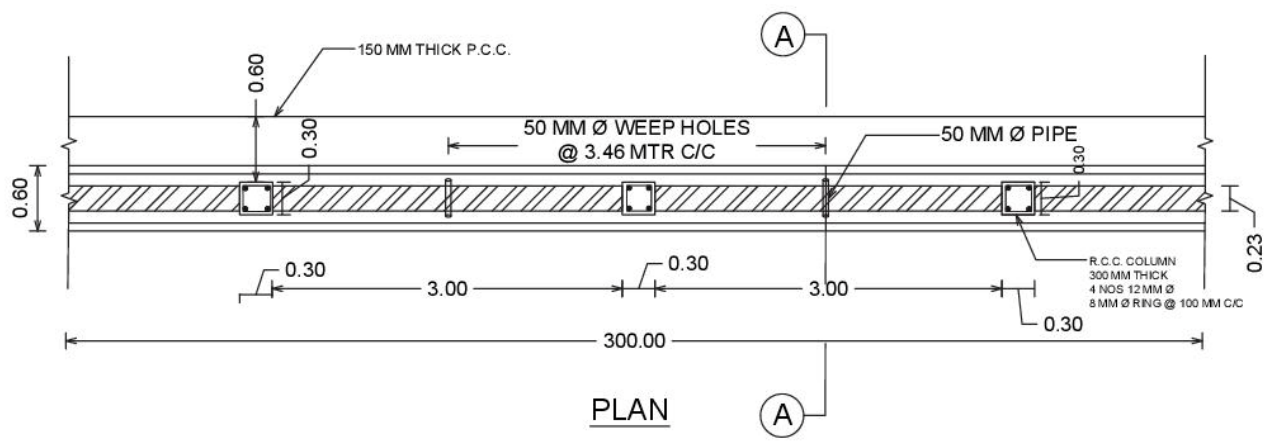

# PLAN

**Annexure - 2**

**Format of certificate**

Certified that the works up to ----- level in respect of construction of ----- at ----- have been executed in accordance with the approved drawing and technical specifications.

Name & Designation

Place:

Date:

Signature

(Official address)

Office seal